

Locomarine

YACHT ROUTER

STANDARD

SERIES 5

The easiest way to stay online.



Installation Manual

version 1.1

Read carefully.

For better understanding check video tutorials on our website.

Register your product for software update notifications.

Thank you.

COPYRIGHT NOTICE

Locomarine Networks d.o.o. reserves the rights to alter the products described in this manual at any time without prior notice. This document contains proprietary information protected by copyright. All rights are reserved. No part of this manual may be reproduced by any mechanical, electronic, or other means in any form without prior written permission of the manufacturer. Information provided in this manual is intended to be accurate and reliable. However, Locomarine Networks d.o.o. assumes no responsibility for use of this manual, nor for any infringements upon the rights of third parties, which may result from such use.

RoHS COMPLIANT

All devices in the Yacht Router series comply with the Restriction of Hazardous Materials (RoHS) Directive. This means that all components used to build Yacht Router and add-on modules are RoHS compliant. The RoHS Directive bans placing on the EU market new electrical and electronic equipment containing more than agreed levels of lead, cadmium, mercury, hexavalent chromium, polybrominated biphenyl (PBB) and polybrominated diphenyl ether (PBDE) flame retardants.

INTRODUCING YACHT ROUTER SOLUTION

Yacht Router with add-on modules is a complete network infrastructure solution for yacht or boat of any size. Yacht Router devices with add-on modules will help you to easily install, setup and control Internet connection on your yacht. The most important part of Yacht Router solution is the software which controls complete system. It is designed by professionals specialized in yacht communication systems in collaboration with experienced yacht captains. The result is a system that is simple to operate, maintain and control. Underneath simple touch user interface, Yacht Router with add-on modules is a solution with an industry level of reliability, performance and unprecedented level of security.

DISCLAIMER AND WARNING

The contents of this manual are well prepared by Locomarine Networks d.o.o.

While we try to improve our equipment at all times, Locomarine Networks d.o.o. shall incur no liability based on contents, updates or modification of the contents, or the lack of contents in this manual.

Because of the nature of wireless communications, transmission and reception of data can never be guaranteed. Data may be delayed, corrupted (i.e. have errors) or be totally lost. Although significant delays or losses of data are rare when wireless devices such as the Yacht Router are used in a normal manner with a well-constructed network, the Yacht Router device and additional modules should not be used in situations where failure to transmit or receive data could result in damage of any kind to the user or any other party, including but not limited to personal injury, death, or loss of property. Locomarine Networks d.o.o. and its affiliates accept no responsibility for damage of any kind resulting from delays or errors in data transmitted or received using the Yacht Router device, or for failure of the Yacht Router device to transmit or receive such data.

The equipment said in this manual must only be used for what it was designed.

Improper operation or installation may cause damage to the equipment or personal injury. Locomarine Networks d.o.o. will not incur any liability of equipment damage or personal injury due to improper use or installation of the equipment. It is strongly recommended to read this manual and the following safety instructions before proceeding to installation or operation.

SAFETY AND HAZARD

Do not operate your Yacht Router and/or add-on modules:

In areas where blasting is in progress.

Where explosive atmospheres may be present including refuelling points, fuel depots, and chemical plants.

Near medical equipment, life support equipment, or any equipment which may be susceptible to any form of radio interference.

In such areas, Yacht Router and add-on modules **MUST BE POWERED OFF**. Otherwise, they can transmit signals that could interfere with this equipment.

In an aircraft, the Yacht Router and add-on modules **MUST BE POWERED OFF**. Otherwise, the Yacht Router and add-on modules can transmit signals that could interfere with various on-board systems and may be dangerous to the operation of the aircraft or disrupt the cellular network. Use of cellular and WIFI equipment in an aircraft is illegal in some jurisdictions. Failure to observe this instruction may lead to suspension or denial of cellular services to the offender, or legal action or both.

IMPORTANT: It is solely on end-user to set transmitting power value for WIFI Booster to comply with regulations of country where product will be used. Regulations and online WIFI power calculators (EIRP - Equivalent Isotropically Radiated Power) are widely available on the Internet. Locomarine Networks d.o.o. cannot be responsible by any means for improper setup. Transmission power is set and regulated via Yacht Router Control software.

IMPORTANT: Exposure to Radio Frequency Radiation.

63 cm minimum distance has to be maintained between the antenna and the occupational user and 142 cm to general public. Under such configuration, the FCC radiation exposure limits set forth for a population/uncontrolled environment can be satisfied.

List of approved antennas:

Omni Directional (pole), model Locomarine MOB 7

ANTENNA INSTALLATION: antennas from other products **MUST NOT BE CO-LOCATED** within 20 cm range to each other to satisfy FCC regulations.

WARNING: It is installer's responsibility to ensure that when using the authorized antennas in the United States (or where FCC rules apply); only those antennas certified with the product are used. The use of any antenna other than those certified with the product is expressly forbidden in accordance to FCC rules CFR47 part 15.204. The installer should configure the output power level of antennas, according to country regulations and per antenna type. Professional installation is required of equipment with connectors to ensure compliance with health and safety issues.

SAFETY INSTRUCTIONS

ELECTRICAL SHOCK HAZARD: Do not open enclosure of the equipment if you are not qualified to do it.

TURN OFF THE POWER IMMEDIATELY IF WATER LEAKS INTO THE EQUIPMENT OR AN OBJECT DROPS INTO THE EQUIPMENT:

Continue operating the equipment could cause electrical shock or fire. Contact your nearest distributor or dealer for service.

DO NOT DISASSEMBLE THE EQUIPMENT OR MODIFY THE EQUIPMENT: Improper disassemble or modification could cause electrical shock, fire, or personal injury.

AVOID OPERATING THE EQUIPMENT WITH WET HANDS: Electrical shocks could be resulted if operating with wet hands.

USE PROPER FUSE: Damage to the equipment or fire could be resulted if using improper fuse.

TURN OFF THE POWER IMMEDIATELY IF THE EQUIPMENT IS EMITTING SMOKE OR FIRE: Continue operating the equipment could cause electrical shock or fire. Contact your nearest distributor or dealer for service.

DO NOT PLACE ANY LIQUID-FILLED CONTAINER ON TOP OF THE EQUIPMENT.

INTRODUCTION

ABOUT YACHT ROUTER STANDARD	7
FEATURES	8
WHAT IS IN THE PACKAGE	9
PORTS AND CONNECTORS	10
INDICATORS	11

INSTALLATION

CONNECTING POWER SUPPLY	12
CONNECTING ADDITIONAL MODULES AND DEVICES	14
SETUP	17

TECHNICAL SPECIFICATIONS

HARDWARE DETAILS	18
NETWORK DETAILS	19
OUTLINE DRAWINGS	20

1.1. ABOUT YACHT ROUTER STANDARD

Yacht Router Standard s5 (*Yacht Router Standard* in further text) is designed for installation on vessels with single or dual satellite Internet source (VSAT, Inmarsat, Iridium etc.). It will provide the ability to establish three vessel networks (e.g. Owner, Guests, Crew) as WIFI and cable version. Each Vessel Network can be simultaneously connected to same or different Internet source.

For example: you can connect Owner network to the internet via VSAT (using additional satellite equipment), Guest network to the Internet over 4G mobile system (via additional Mobile Expander module) while in the same time Crew network can access Internet over WIFI Hotspot in marina (via additional WIFI Booster module).

For larger vessels where single WIFI access point is not enough to cover all vessel areas, multiple Network Extender modules can be installed.

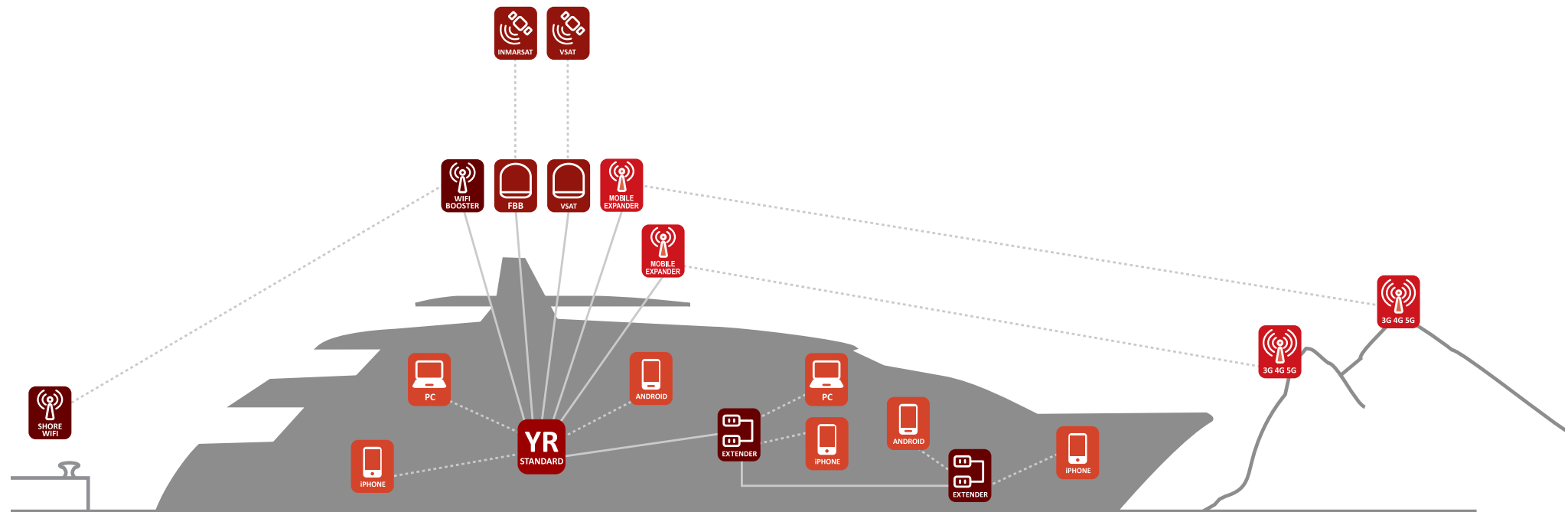

Schematic drawing of Yacht Router Standard capability and connectivity.

1.2. FEATURES

- 2x SAT port (for satellite Internet systems, ADSL, mobile routers)
- Optional High power 2G/3G/4G module (30+ Nautical miles¹)
- Optional high power WIFI Booster for long distance WIFI connectivity (10+ NM²)
- 3x Vessel WIFI network
- 3x Vessel Network LAN port
- 5x Backbone LAN port
- 2,4 + 5 GHz high power MIMO WIFI (b/g/n + a/n/ac)
- Hotel type hotspot on one Vessel Network.
- Multiple Mobile Expander support
- Multiple Network Extender support
- Online Remote support
- Free GPS tracking and anchor alarm
- Wide range DC power input (10-30 V)
- Compatible with Furuno, Simrad, Lowrance, B&G, Garmin, Maretron, Sonos, Apple Airplay and other IP based systems

¹ Achieved with 9dBi outdoor antenna. As actual range depends on many factors Locomarine Networks d.o.o. do not guarantee specified range of connectivity.

² Achieved with 9dBi outdoor antenna and VIP mobile provider. As actual range depends on many factors Locomarine Networks d.o.o. do not guarantee specified range of connectivity.

1.3. WHAT IS IN THE PACKAGE

When shipped, all devices are wrapped in plastic bags that protect them from humidity. Devices are then placed into a cardboard box. A bag containing accessory items is placed inside the box too. List of all included components is enclosed in the package.



- 1** - Yacht Router Standard, LYR-S05 or LYR-S05-US, 1 pcs
- 2** - Deck mount (YR Standard s5), DMN-01, 2 pcs
- 3** - Fixing screw, FSC-01, 8 pcs
- 4** - AC/DC power supply 24V/2.5A, PSU-06, 1 pcs
- 5** - CAT5 cable (with connectors, 1m), CAT5-02, 2 pcs
- 6** - DC power cable with connector 2 m, PWC-01, 1 pcs
- 7** - DC power cable adaptor (male to wires), PWC-06
- 8** - AC power cable 1.5 m, PWC-05
- 9** - Manuals & control software (on USB stick), QIG-00, 1 pcs
- 10** - Fuse 1.5 A, FUS-01, 2 pcs

1.4. PORTS AND CONNECTORS

Yacht Router Standard is equipped with following ports and connectors.

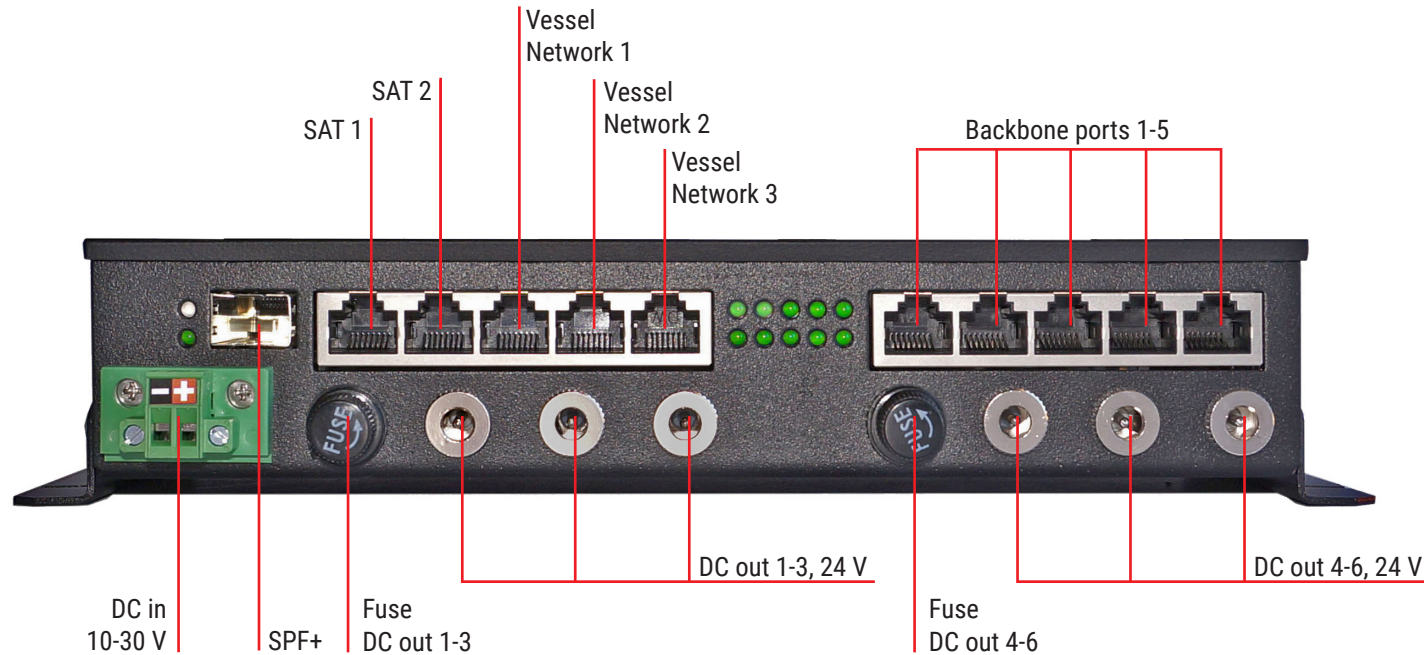

SAT 1 and SAT 2 ports

Satellite equipment input ports (VSAT, FBB, Iridium etc). It can also be used for any other Internet source equipment like ADSL or mobile router (2G/3G/4G).

Vessel Networks 1-3 ports

Ethernet LAN ports for various devices (e.g. computers, printers, IP cameras) that you want to integrate with dedicated Vessel Network. Each port dedication can be changed on demand (e.g. Vessel Network 1 LAN port can be set to Backbone network).

Backbone ports

Backbone ports are part of Backbone network. Backbone network is network dedicated for communication between various Yacht Router equipment like Mobile Expander, WIFI Booster, Network Extender etc. **Backbone network cannot provide Internet access.** Each port dedication can be changed on demand (e.g. Backbone LAN port 3 can be set to Vessel network 2).

1.5. INDICATORS

Yacht Router Standard is equipped with multiple LED indicators.

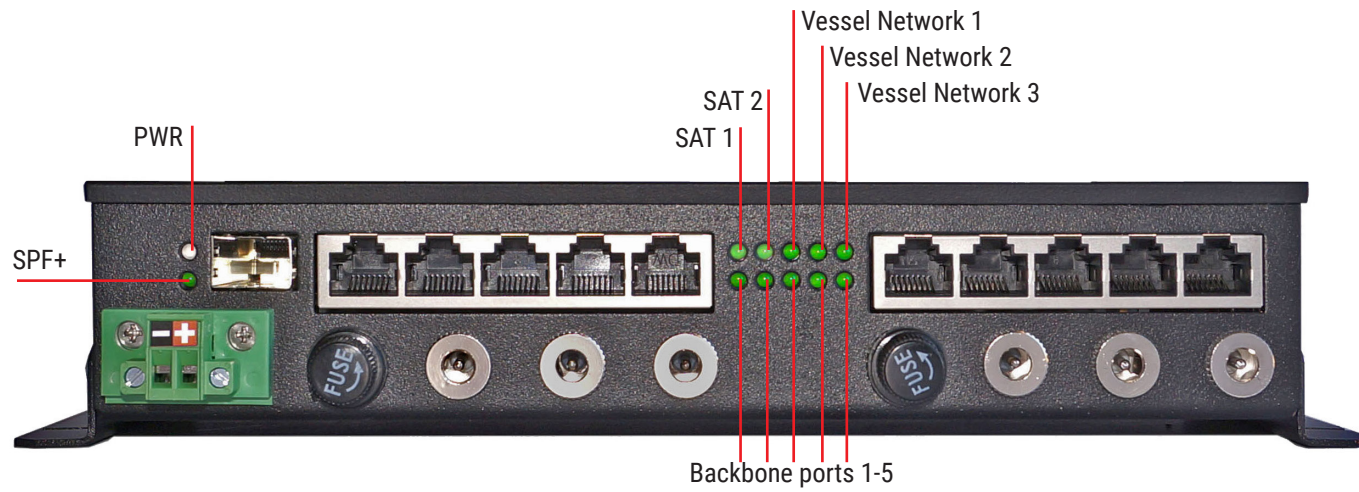

2.1. CONNECTING POWER SUPPLY

There are two ways to power Yacht Router Standard:

- directly from boat battery (10-30 V DC)
- via supplied AC/DC power supply and DC power cable adaptor

Most common way is to connect Yacht Router Standard directly to vessel battery using 2 m supplied DC power cable. Power cable consist of RED and BLACK wire. Connect RED wire to positive (+) and BLACK wire to negative (ground -) power source on your vessel power supply system (battery).



IMPORTANT | Wrongly connected DC power cable can damage Yacht Router and void a warranty.
Voltage lower than 10 V and higher than 30 V can damage Yacht Router and void a warranty.

Connection via supplied AC/DC power supply and DC power cable adaptor.



2.2. CONNECTING ADDITIONAL MODULES AND DEVICES

You can upgrade your Yacht Router with following equipment:

WIFI Booster

It is device for long-range WIFI connection to shore WIFI networks (e.g. marina Hotspot). WIFI Booster is waterproof Power-Over-Ethernet device that you can install directly on a mast or radar arch. As you can attach WIFI antenna directly to the WIFI Booster there is no coax cable signal loss. With optional high gain outdoor antenna, you can expect up to 10 NM connection, even further in ideal conditions.

Mobile Expander

It is device that will give you possibility to connect Yacht Router to 2G/3G/4G mobile networks. It is equipped with high power modem and with additional outdoor antennas it is possible to get 30+ NM offshore connection. Mobile Expander is equipped with GPS receiver and miniature GPS antenna for Remote Tracking and Anchor alarm service.

Network Extender

Network Extender is a device that will help you to extend Vessel Networks WIFI coverage on larger boats or yachts. It is designed to work both on 2.4 and 5 GHz (b/g/n + a/n/ac) frequency range. It is connected to Yacht Router via single PoE (Power over Ethernet) cable for simultaneous power and data transfer. Each Network Extender is equipped with four additional LAN ports so you can easily connect more Network Extenders or other devices. Network Extender is essential component in installations on larger yachts and vessels. It significantly simplifies installations resulting in huge saving of Ethernet cables and labour.

NMEA0183 to LAN converter

It will convert any NMEA0183 data to TCP so you can receive it on your WIFI or LAN connected device. It is perfect solution in a combination with any Yacht Router as it will give you ability to receive all NMEA data (depth, speed, wind etc.) inside your navigation software on your wireless or wired device. In a combination with Cloud Service, you will be able to receive NMEA data remotely to check your boat position, wind speed, COG, SOG etc. NMEA0183 to LAN converter is compatible with every navigation software that can receive NMEA data over TCP protocol.

Touch Screen Controller

Touch Screen Controller is a dedicated device that will give you ability to setup Yacht router and easily control wireless networks and Internet connections on your vessel. It is embedded device with the same level of functionality as control software that is used on a computer running Windows OS that control Yacht Routers with addition of several features regarding built-in upgrade and software version control functionality.

Check each product manuals for more details or visit www.yachtrouter.com for more details.

Example of various modules and devices connected to the system.

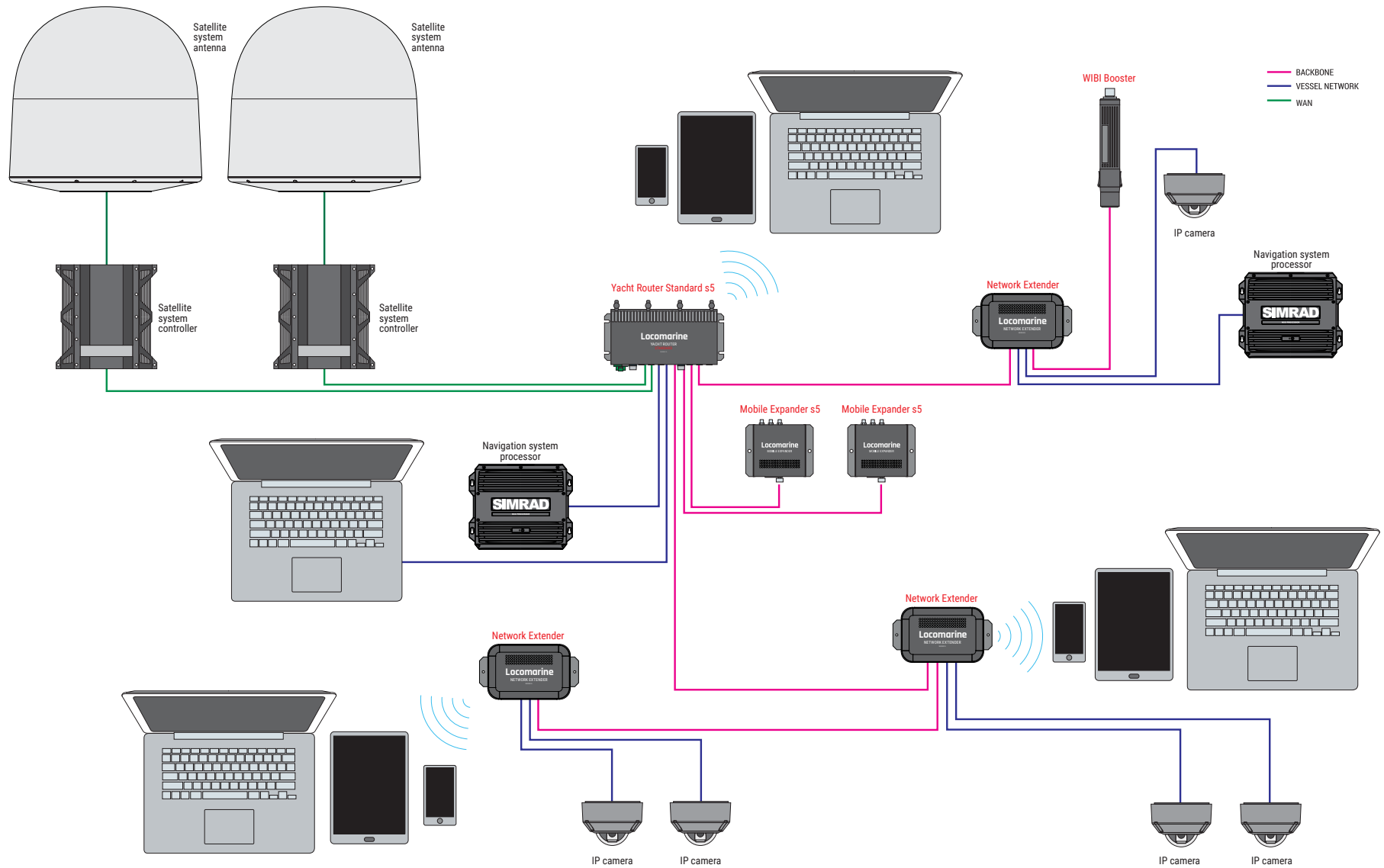

2.3. SETUP

Once you finished hardware installation you need to install Yacht Router Control software to setup and control Yacht Router:



Once you install the software refer to USER MANUAL how to use it. It is available for download on our website www.yachtrouter.com

You can also check VIDEO TUTORIALS on our website www.yachtrouter.com

3.1. HARDWARE DETAILS

WAN, LAN, Backbone ports

Ethernet WAN ports: 2

Ethernet LAN ports: 3

Ethernet Backbone ports: 5

Max. data rate on WAN/LAN/Backbone port: 1 Gbps

Add-on Modules support

WIFI Booster: 1

Mobile Expander: 3

Network Extender: 20

NMEA0183 to LAN converter: yes

Touch Screen Controller: yes

Vessel networks (WIFI/LAN)

Max. number of networks: 3

Supported standard: 2.4 GHz (b/g/n), 5 GHz (a/n/ac)

Max. WIFI data rates on 2.4 GHz: 300 Mbps

Max. WIFI data rates on 5 GHz: 1733 Mbps

Max. WIFI transmit power on 2.4 GHz: 29/794 dBm/mW

Max. WIFI transmit power on 5 GHz: 33/1995 dBm/mW

Sensitivity of integrated antenna (2.4/5 GHz): 3/3 dB

Power, environment and dimensions

DC power supply input range: 10-30 V

Max. power consumption: 44 W

Operating temperature range for internal unit: -10 to +50 °C

Operating humidity range: 5-95 % non-condensing

IP Protection: IP50

Dimension (WxDxH, without antennas): 255 x 135 x 48 mm

3.2. NETWORK DETAILS

Yacht Router Standard has reserved IP ranges that cannot be used by other connected equipment:

Support network

10.10.10.0/24

Reserved range

10.80.0.0/12

Yacht Router Standard IP reservation details:

Backbone Network

10.80.0.0/16

Vessel Network 1

Gateway: 10.81.0.1

Free static range: 10.81.0.20 - 10.81.0.99

DHCP: 10.81.0.100 - 10.81.255.254

DNS: 10.81.0.1

Vessel Network 2

Gateway: 10.82.0.1

Free static range: 10.82.0.20 - 10.82.0.99

DHCP: 10.82.0.100 - 10.82.255.254

DNS: 10.82.0.1

Vessel Network 3

Gateway: 10.83.0.1

Free static range: 10.83.0.20 - 10.83.0.99

DHCP: 10.83.0.100 - 10.83.255.254

DNS: 10.83.0.1

3.3. OUTLINE DRAWINGS

All dimensions in mm.

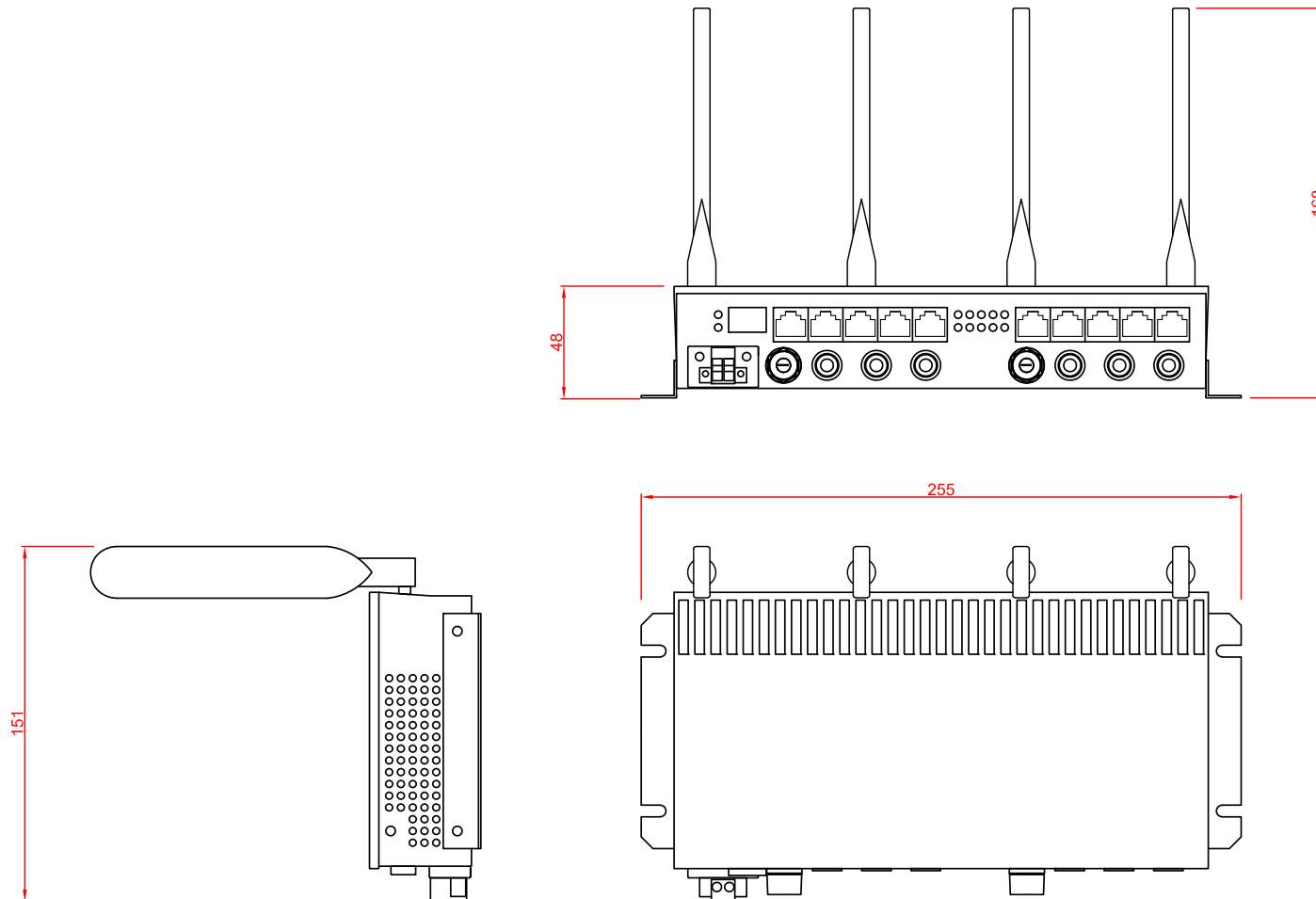

Yacht Router Standard - Series 5

LOCOMARINE NETWORKS d.o.o. LIMITED FACTORY WARRANTY

Locomarine Networks d.o.o. manufactures marine electronic products which are marketed and supported worldwide via the Locomarine Networks d.o.o. distributor, dealer and partner network. Each and every Locomarine Networks d.o.o. distributor, dealer and partner is committed to service and support the products in accordance with the market's needs and requirements. In addition, the Locomarine Networks d.o.o. distributor, dealer and partner networks are obliged to support the products irrespective of who sold and installed the product. Locomarine Networks d.o.o. Limited Factory Warranty for Yacht Router products can be downloaded from www.yachtrouter.com under Support/Download section.

DECLARATION OF CONFORMITY

Hereby, Locomarine Networks d.o.o. declares that this Yacht Routers and add-on modules are in compliance with the essential requirements and other relevant provisions of Directive 2014/53/EC. Declaration of Conformity is available for download on www.yachtrouter.com.

IMPORTANT: It is solely on end-user to set transmitting power value for all Yacht Router WIFI components to comply with regulations of country where product will be used. Regulations and online WIFI power calculators (EIRP - Equivalent Isotopically Radiated Power) are widely available on the Internet. It is solely up to user to comply with country regulations and Locomarine Networks d.o.o. cannot be responsible by any means for improper setup. Transmitting power is set and regulated via Yacht Router Control software.

FCC INTERFERENCE STATEMENT

This device contains FCC ID: TV74011GS-5HQ2HD, TV7R11E2HPND. This equipment has been tested and found to comply with the limits for a Class B digital device, pursuant to Part 15 of the FCC Rules. These limits are designed to provide reasonable protection against harmful interference in a residential installation.

This equipment generates, uses and can radiate radio frequency energy and, if not installed and used in accordance with the instructions, may cause harmful interference to radio communications. However, there is no guarantee that interference will not occur in a particular installation. If this equipment does cause harmful interference to radio or television reception, which can be determined by turning the equipment off and on, the user is encouraged to try to correct the interference by one of the following measures:

- Reorient or relocate the receiving antenna.
- Increase the separation between the equipment and receiver.
- Connect the equipment into an outlet on a circuit different from that to which the receiver is connected.
- Consult the dealer or an experienced radio/TV technician for help.

FCC Caution: Any changes or modifications not expressly approved by the party responsible for compliance could void the user's authority to operate this equipment.

This device complies with Part 15 of the FCC Rules. Operation is subject to the following two conditions: (1) This device may not cause harmful interference, and (2) this device must accept any interference received, including interference that may cause undesired operation.

This device and its antennas must not be co-located or operated in conjunction with any other antenna or transmitter.

IMPORTANT: Exposure to Radio Frequency Radiation.

63 cm minimum distance has to be maintained between the antenna and the occupational user and 142 cm to general public. Under such configuration, the FCC radiation exposure limits set forth for a population/uncontrolled environment can be satisfied.

List of approved antennas:

Omni Directional (pole), model Locomarine MOB 7

ANTENNA INSTALLATION: antennas from other products **MUST NOT BE CO-LOCATED** within 20 cm range to each other to satisfy FCC regulations.

Antenna Installation. **WARNING:** It is installer's responsibility to ensure that when using the authorized antennas in the United States (or where FCC rules apply); only those antennas certified with the product are used. The use of any antenna other than those certified with the product is expressly forbidden in accordance to FCC rules CFR47 part 15.204. The installer should configure the output power level of antennas, according to country regulations and per antenna type. Professional installation is required of equipment with connectors to ensure compliance with health and safety issues.

INDUSTRY CANADA NOTICE TO USERS

Notice: To satisfy IC RF exposure requirements for mobile and base station transmission devices, a separation distance of 63 cm or more should be maintained between the antenna of this device and persons during operation. To ensure compliance, operation at closer than this distance is not recommended. The antenna(s) used for this transmitter must not be co-located or operated in conjunction with any other antenna or transmitter.

Avis: Pour répondre à la IC d'exposition pour les besoins de base et mobiles dispositifs de transmission de la station, sur une distance de séparation de 63 cm ou plus doit être maintenue entre l'antenne de cet appareil et les personnes en cours de fonctionnement. Pour assurer le respect, l'exploitation de plus près à cette distance n'est pas recommandée. L'antenne (s) utilisé pour cet émetteur ne doit pas être co-localisés ou fonctionner conjointement avec une autre antenne ou transmetteur.

